

SA8605W

23321
ID010408

60cm built-in, white enamel, tall tank



85.5cm tall, 57cm deep — suits flush alignment to adjacent cabinetry

tall tank — 68.5cm

three top-basket heights

bottom basket, plates to 34.5cm

14 place settings

5 main programs

4 half-load programs (top basket selection)

16-litre full load consumption on Daily program

3 wash temperatures — 40°, 65°, 70°C

4 rinse temperatures — ambient, 45°, 68°, 70°C

residual heat hot air drying

special extra Hygiene program for very dirty dishes and pans with dried-on residue — prewash at 45°C, wash at 70°C, two cold rinses, then a final hot rinse at 70°C followed by residual heat hot air dry

orbital wash technology

extra multi-directional ceiling wash wand

Pex hosing

six-stage total water security

five-stage self-cleaning filter (1st & 5th stage stainless steel)

hot or cold water connection

concealed high-speed in-line water heater

ultra-quiet 35dBA fully loaded and operating

equal water pressure top and bottom baskets

connect to mains pressure or unequal (gravity) pressure

built-in, underbench or wall

white enamel

(18/10 commercial grade 304 No 4 non magnetic)

— control panel

— door

— kickplate

fully electronic touch button controls

new graphite rilsen baskets

new design extension racking for top basket

full stainless steel interior

tar-sealed carcass plus packed foam and rockwool

blanketing for sound and energy insulation

SA8605W

23321
ID010408

60cm built-in, white enamel, tall tank

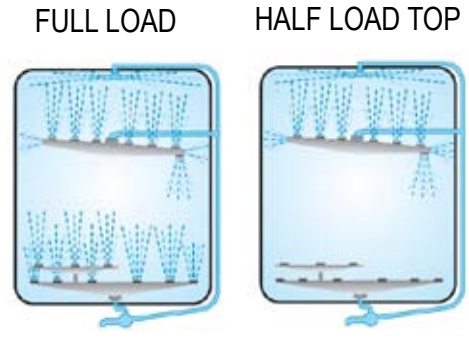
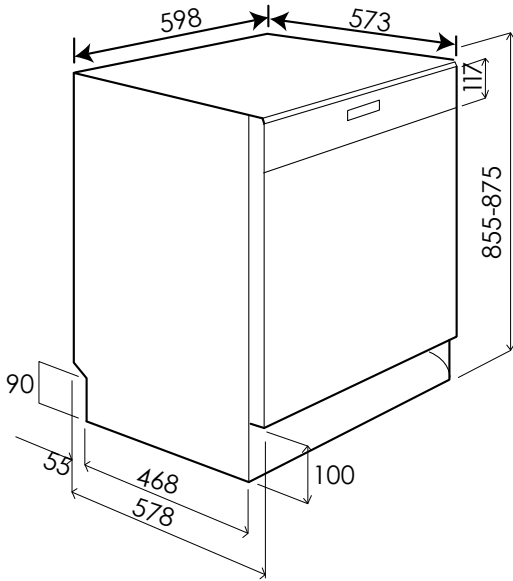

Water mains pressure allowed —
minimum 5Ncm/2
 50Kpa
 3psi
 0.5bar
maximum 1000Ncm/2
 1000Kpa
 110psi
 10bar
 Suitable for mains, gravity feed and tank pressures

electricity supply 240 volt 50 Hz
 electricity connection 10 Amp GPO
 concealed element 2100 Watt
 wash motor 150 Watt
 pump motor 20 Watt
 max current 9.4 Amp

Water connection hot or cold
 Pex hose tolerance 90°C
 Recommended max intake 65°C

packaged dimensions
 940mm x 680mm x 650mm = 0.42m³
 gross weight 62kg
 net weight 53.4kg

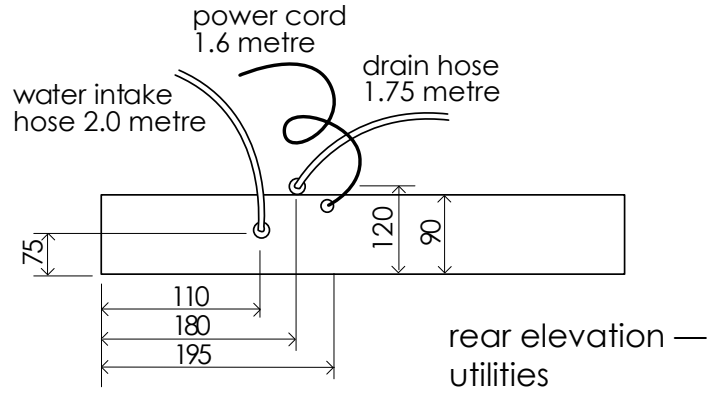
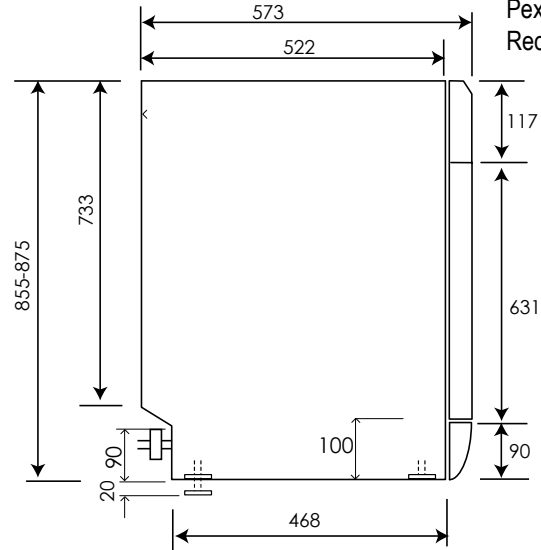

side elevation

rear elevation —
utilities

NB drawings are not to scale — they are to assist only

Wash times can be substantially reduced if a hot water connection is practicable

Program	Description	Selections	Prewash	Wash	Cold Rinse	Hot Rinse	Drying	Time (mins)	Consumption	
									litres	Kwh
Soak	rinse & hold progressive loading		cold	-	-	-	-	12	7	0.03
Normal Eco	not very dirty but with dry residue		cold	40°C	1	45°C	yes	123	16.9	0.75
Extra Hygiene	very dirty and dried-on residue		45°C	70°C	2	70°C	yes	110	20	1.75
Daily	normally dirty without dry residue		-	65°C	1	68°C	yes	95	16	1.57
Normal	normally dirty with dry residue		cold	65°C	1	68°C	yes	95	20	1.42

Warning: technical specifications and product sizes can be varied by the manufacturer without notice.
 Cutouts for appliances should only be by physical product measurements. The above information is indicative only.

